



The orientation of the lamp and the design of the reflector influence the performance characteristics of the light source in the following ways:

Optical Power

The obvious way to increase the optical output of a light source is to employ a bigger lamp. A higher power lamp, however, will not necessarily result in higher optical output from a light source. Since light is emitted by the lamp in all directions, the important thing is not the amount of light emitted, but the amount of light collected.

The OBB light sources have the highest optical power output because they have the highest collection efficiency. We collect and focus emitted light with a single optical element: an ellipsoidal reflector. Because the ellipsoid encloses a large portion of the solid angle about the arc lamp, over 65 % of the lamp's emission is collected and focused at the output.

Compare this to the typical performance of a traditional lamp housing design with a spherical reflector and condenser lens where roughly 10 % of the light is collected. Using identical lamps, the total optical output of our light source is about seven times higher than the traditional housing. To get the same optical output as our light source with a 100 watt lamp, a traditional housing would require a 1000 watt lamp!

An ellipsoid has two focal points. With the arc lamp precisely positioned at one focal point, the collected light is focused at the second focal point. In your experiment, the sample, the monochromator slit or the fiber optic bundle would be positioned at the second focal point.

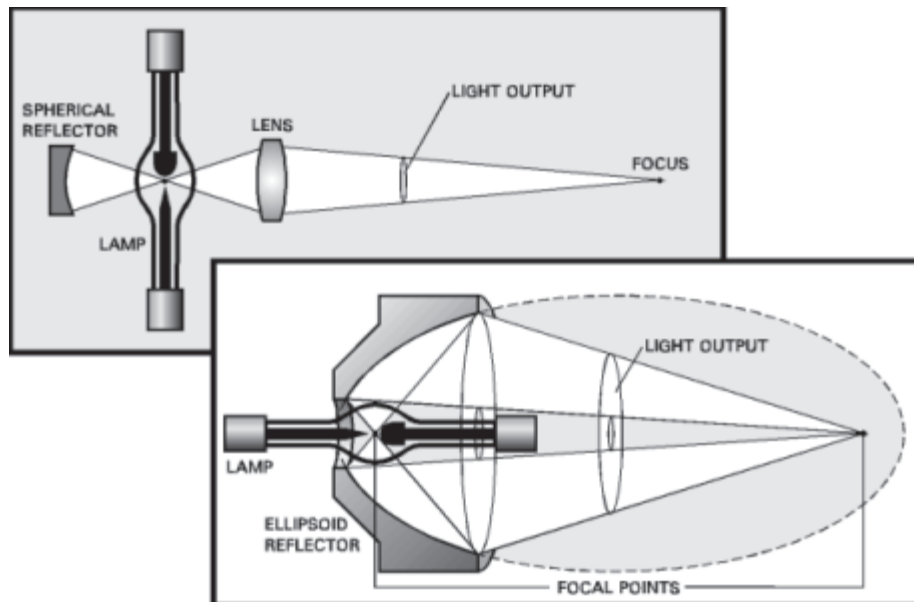

Power Density

For many experiments involving the illumination of a relatively small area, the power density of a light source is a critical specification. Optical power density is a function of the output of the lamp and the size of the area illuminated. Note, however, that increasing the lamp power does not necessarily increase the power density; in fact, it can actually reduce it. Assuming the optics are the same, the maximum practical power density is a function of arc size.

For example, a 75 watt lamp has a luminous area of 0.2 by 0.5 mm, or 0.1 sq. mm. A typical 450 watt lamp has a luminous area of 0.9 by 2.7 mm, or 2.43 sq. mm. The illuminated area from the 450 watt lamp is 24 times greater than the 75 watt lamp, but it has only six times more power. The power density of the 75 watt lamp, then, is four times higher than that of the 450 watt lamp.





Stability

The interior of an arc lamp housing in operation can exceed 150 degrees Celsius. Thermal distortion of the reflector is of concern, since it is the only optical element in the system. Deformation of the ellipsoid shape can dramatically reduce the useable output of the illuminator. The proprietary, thermally-matched optics used OBB Corp guarantee that the shape of the ellipsoidal reflector remains accurate during operation.

Uniformity

Neither a vertical nor a horizontal arc lamp produces perfectly uniform illumination. The majority of the light is produced near the cathode. When mounted vertically, the illumination between the electrodes is quite uneven from top to bottom. In the horizontal position, convection currents within the lamp cause slight arc wander. We have found that the ellipsoidal reflector produces the most consistent intensity at the output when the lamp is operated in the horizontal position.

Comparative field-test results:

“High Efficiency lamp housing yields 20X better sensitivity...lower operating cost.”

In an independent comparison of OBB's Lamp Housing with elliptical reflector vs. a competitor's condenser (lens/reflector) housing, a 100 watt Hg lamp was mounted in the OBB Lamp Housing, and a 350 watt Hg lamp was mounted in the competitor's conventional lamp housing. Both lamps were focused through the same monochromator, and then imaged onto a capillary flow cell "sample". The flow cell emission was then imaged onto a line scan camera, with each pixel representing 1 mm of sample length.

As the attached graphs indicate, the smaller OBB lamp housing produced 5.5 times more emission signal with the less expensive 100 watt lamp than the larger, conventional lamp housing produced with the more expensive 350 watt lamp.

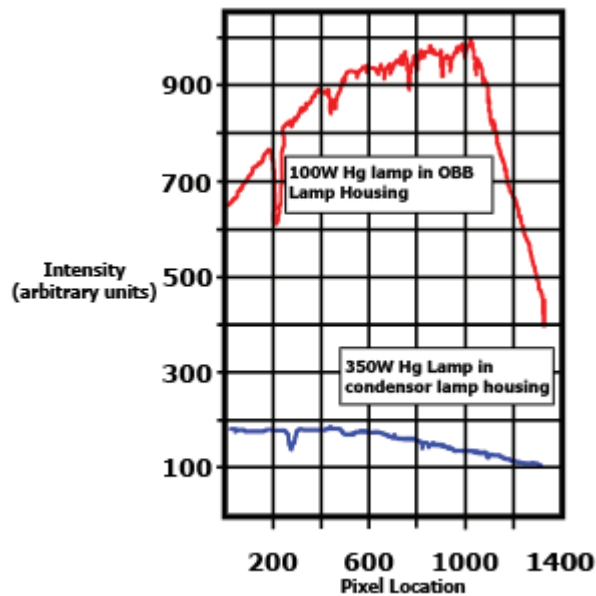

Test and data courtesy of Dr. Heinrich Roder, Fox Chase Cancer Institute, Phila., Pa.

