



Optical Building Blocks Corp.

Technical Note: EasyLife's Patented Detection - Methodology

The EasyLife V™ utilizes the OBB-patented stroboscopic detection system. It comprises a photomultiplier (PMT) and controlling electronics. The PMT is pulsed at the rep rate and in sync with the pulsed LED source. Software-controlled electronics provides a very precise timing between the LED flash and the pulse controlling the PMT gain and the temporal window. A block diagram of the system is depicted in Fig. 1.

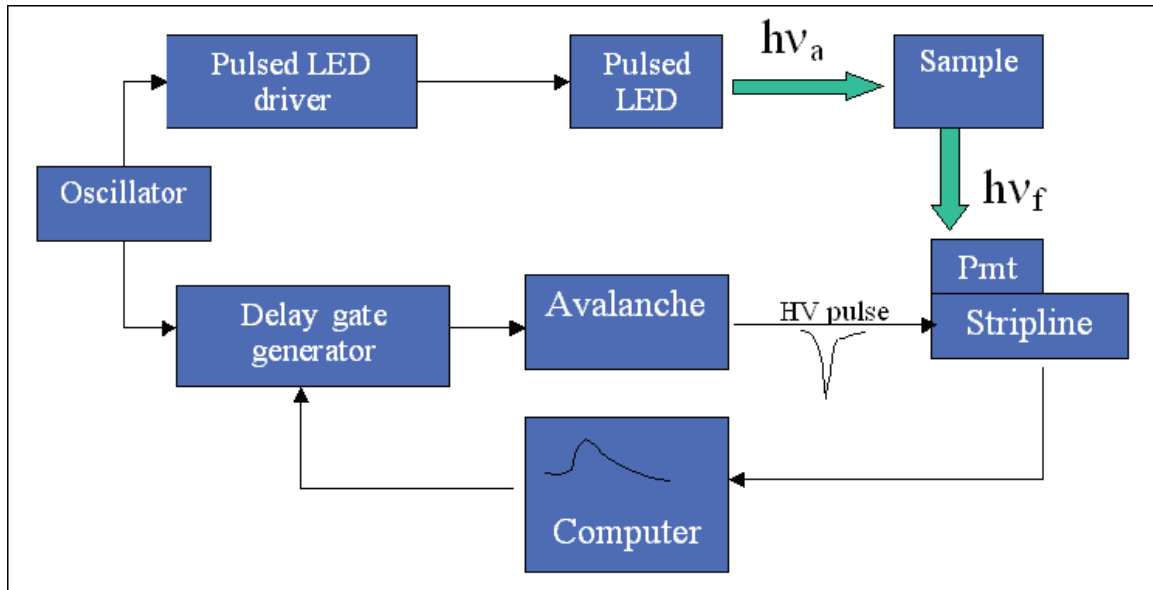

Fig. 1. Block diagram of the EasyLife stroboscopic system

A master clock (oscillator) generates electrical pulses at a fixed frequency of 25 KHz. The pulses are routed simultaneously to a pulsed LED driver and to a digital delay gate generator (DGG) unit.

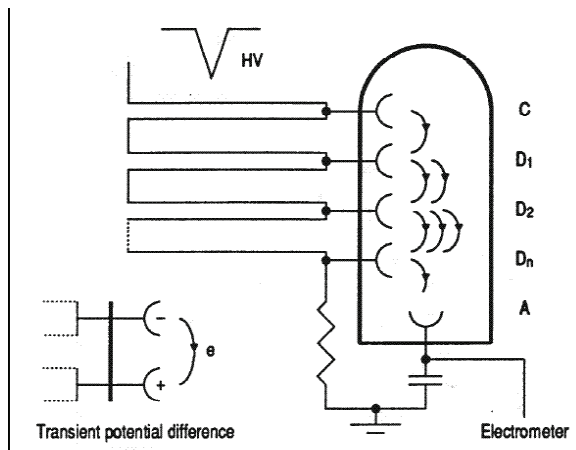

Fig. 2. PMT stripline wiring and the principle of operation of the stroboscopic detector. C, Di and A denote the photocathode, dynodes and anode, respectively.

The LED flash excites a sample, which subsequently emits fluorescence. At the same time a pulse synchronized with the LED driver triggers the DGG, which outputs a delayed TTL pulse.

The DGG is under computer control and the value of the TTL pulse delay is determined in the acquisition software. The delayed pulse triggers an avalanche circuit, which provides a high voltage pulse for the detection circuitry. This pulse creates the gain and the temporal discrimination gate for the photomultiplier.

matched to the time it takes for electrons to travel between each of the dynode pairs (see Fig. 2). The high-voltage pulse HV synchronized with the LED flash is then injected into the dynode chain D1. This pulse causes a transient potential difference between each dynode as it travels down the delay line connecting each dynode. The net result is that the packet of electrons started by a photoelectron ejected from the photocathode C is selectively amplified as it passes down the dynode chain. Of significance to the stroboscopic technique is that the PMT is sensitive to photons arriving at the photocathode C only when the high voltage pulse HV is between the photocathode C and the first dynode D1.



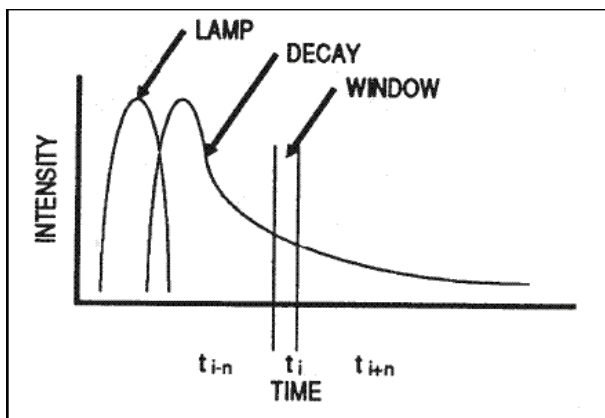
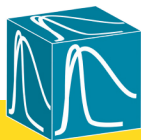

Fig 3. Time gating of the detector by the stroboscopic technique. The window for detection ($t_i - \delta$, $t_i + \delta$) moves across the fluorescence decay with step increments as small as 25 ps.

As a result, a narrow integration window of amplification is formed, which can be moved across the fluorescence decay and the fluorescence intensity at different delay times is recorded. The position of the gate with respect to the fluorescence decay is shown schematically in Fig. 3. At each gate position the electron pulses from the PMT are integrated by an R-C circuit to a DC signal, which is then fed to a 12-bit A/D converter. The integration time is controlled by user providing a means for signal-averaging.

A unique feature of the strobe is the ability to measure decays with the use of non linear timescale. This is possible because the software controls the delayed output of the DGG and the detection gate. The EasyLife employs arithmetic progression and logarithmic timescale acquisition protocols in addition to the conventional linear timescale. These non-linear timescale protocols enhance the lifetime resolving power and allow for the acquisition of complex decays with underlying lifetimes differing by orders of magnitude, from less than 100 ps to approx. 3 μ s, using fewer data points than would be required with the linear timescale.

The stroboscopic detection is inherently fast; this is because it measures fluorescence intensity directly and, unlike photon counting techniques, is not limited by photon counting statistic and can therefore take advantage of high intensity fluorescence.

